

1

2

3

4

5

6

A

B

C

D

A

B

C

D

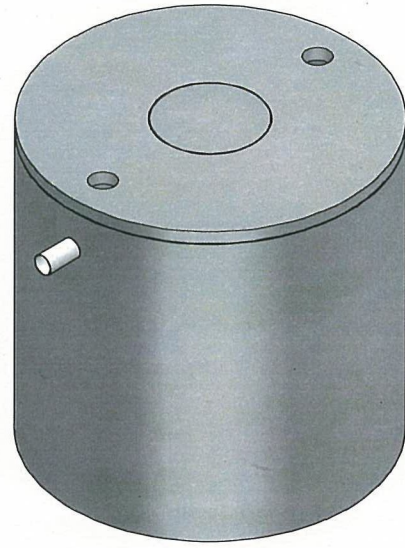
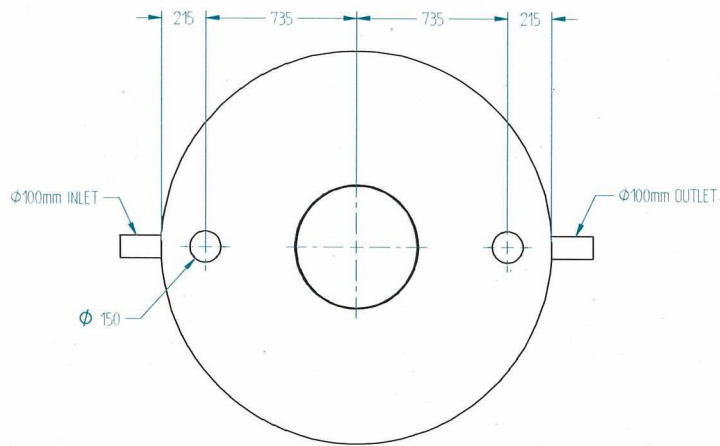

APPROVED

18 AUG 2010

DEPARTMENT OF HEALTH, N.S.W.

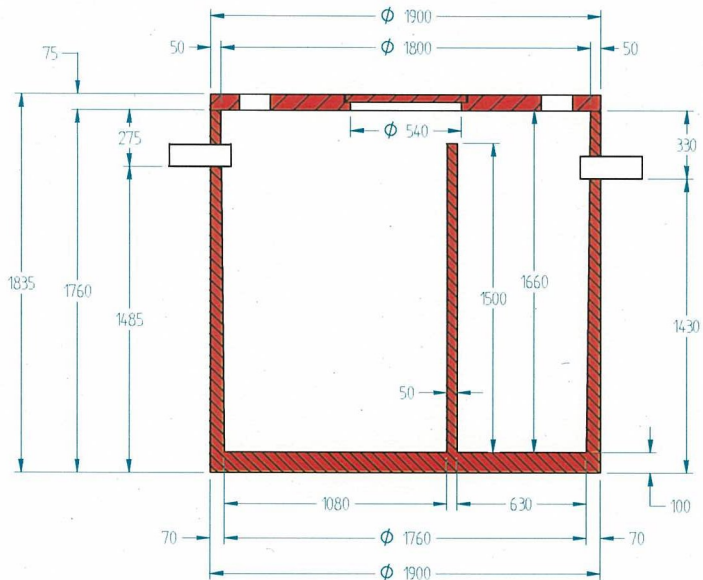

NOTES:

1. SEPTIC TANKS TO BE MANUFACTURED AND TESTED IN ACCORDANCE WITH AS/NZS 1546.1:2008
2. CONCRETE STRENGTH = 40MPa
3. CONCRETE TO BE VIBRATED TO ENSURE WELL COMPACTED CONCRETE
4. TANKS TO BE REINFORCED WITH FIBRE STEEL
5. LIFTING TO BE "REID SWIFT LIFTS" 4 x 2.5 TONNE FOOT ANCHORS CAST INTO BASE OF THE TANK, 3 x 1.3 TONNE ANCHORS CAST INTO TANK LIDS

		PROJECT: SEPTIC TANK	
	<small>UNLESS OTHERWISE SPECIFIED ALL DIMENSIONS ARE IN MM</small>	TITLE: 3150L CONCRETE TANK ASSY NSW HEALTH CERTIFICATION DRAWING	
COPYRIGHT <small>THIS DRAWING AND DESIGN ARE COPYRIGHT PROPERTY OF ECONOCYCLE AND ARE NOT TO BE REPRODUCED OR TRANSMITTED IN ANY FORM WITHOUT WRITTEN PERMISSION</small>	<small>SCALE:</small> DO NOT SCALE	<small>DATE PLOTTED:</small> 27/07/2010	<small>EDAT/TREAT:</small> -
	<small>DRAWN BY:</small> P. MCKAY	<small>DRAWING LAST MODIFIED BY:</small> P. MCKAY	<small>PART #:</small> 124_1310
<small>MODELLED BY:</small> P. MCKAY	<small>MODEL LAST MODIFIED BY:</small> P. MCKAY	<small>REVISION:</small> 1.B	<small>SHEET No:</small> 1 OF 1

1

2

3

4

5

6